



GE Power Systems

***Power Systems for
the 21st Century –
“H” Gas Turbine
Combined-Cycles***

R.K. Matta
G.D. Mercer
R.S. Tuthill
GE Power Systems
Schenectady, NY

Contents

Abstract 1

Background and Rationale for the H System™ 2

Conceptual Design 3

The Case for Steam Cooling 3

H Technology, Combined-Cycle System 4

H Product Family and Performance 4

System Strategy and Integration 5

H Gas Turbine 7

Compressor Overview 7

Combustor Overview 7

Turbine Overview 7

Gas Turbine Validation: Testing to Reduce Risk 8

Compressor Design Status 9

Combustor Design Status 10

Fuel Injection Design Status 10

Turbine Design Status 12

Gas Turbine Factory Tests 14

Validation Summary 15

Conclusion 16

List of Figures 17

List of Tables 17

Abstract

This paper provides an overview of GE’s *H System*[™] technology and describes the intensive development work necessary to bring this revolutionary technology to commercial reality. In addition to describing the magnitude of performance improvement possible through use of *H System*[™] technology, this paper discusses the technological milestones during the development of the first 9H (50 Hz) and 7H (60 Hz) gas turbines.

To illustrate the methodical product development strategy used by GE, this paper discusses several technologies which are essential to the introduction of the *H System*[™]. Also included herein are analyses of the series of comprehensive tests of materials, components and subsystems which necessarily preceded full-scale field testing of the *H System*[™]. This paper validates one of the basic premises on which GE started the *H System*[™] development program: Exhaustive and elaborate testing programs minimize risk at every step of this process, and increase the probability of success when the *H System*[™] is introduced into commercial service.

In 1995, GE, the world leader in gas turbine technology for over half a century, introduced its new generation of gas turbines. This *H System*[™] technology is the first gas turbine ever to achieve the milestone of 60% fuel efficiency. Because fuel represents the largest individual expense of running a power plant, an efficiency increase of even a single percentage point can substantially reduce operating costs over the life of a typical gas-fired, combined-cycle plant in the 400 to 500 megawatt range.

The *H System*[™] is not simply a state-of-the-art gas turbine. It is an advanced, integrated, combined-cycle system every component of which is optimized for the highest level of performance.

The unique feature of an H technology, combined-cycle system is the integrated heat transfer system, which combines both the steam plant reheat process and gas turbine bucket and nozzle cooling. This feature allows the power generator to operate at a higher firing temperature, which in turn produces dramatic improvements in fuel-efficiency. The end result is generation of electricity at the lowest, most competitive price possible. Also, despite the higher firing temperature of the *H System*[™], combustion temperature is kept at levels that minimize emission production.

GE has more than two million fired hours of experience in operating advanced technology gas turbines, more than three times the fired hours of competitors’ units combined. The *H System*[™] design incorporates lessons learned from this experience with knowledge gleaned from operating GE aircraft engines. In addition, the 9H gas turbine is the first ever designed using “Design for Six Sigma” methodology, which maximizes reliability and availability throughout the entire design process. Both the 7H and 9H gas turbines will achieve the reliability levels of our F-class technology machines.

GE has tested its *H System*[™] gas turbine more thoroughly than any system previously introduced into commercial service. The *H System*[™] gas turbine has undergone extensive design validation and component testing. Full-speed, no-load testing (FSNL) of the 9H was achieved in May 1998 and pre-shipment testing was completed in November 1999. This *H System*[™] will also undergo approximately a half-year of extensive demonstration and characterization testing at the launch site.

Testing of the 7H began in December 1999, and full-speed, no-load testing was completed in February 2000. The 7H gas turbine will also be subjected to extensive demonstration and characterization testing at the launch site.

Background and Rationale for the H System™

The use of gas turbines for power generation has been steadily increasing in popularity for more than five decades. Gas turbine cycles are inherently capable of higher power density, higher fuel efficiency, and lower emissions than the competing platforms. Gas turbine performance is driven by the firing temperature, which is directly related to specific output, and inversely related to fuel consumption per kW of output. This means that increases in firing temperature provide higher fuel efficiency (lower fuel consumption per kW of output) and, at the same time, higher specific output (more kW per pound of air passing through the turbine).

The use of aircraft engine materials and cooling technology has allowed firing temperature for GE’s industrial gas turbines to increase steadily. However, higher temperatures in the combustor also increase NO_x production. In the “Conceptual Design” section of this paper, we describe how the GE *H System*™ solved the NO_x problem, and is able to raise firing temperature by 200°F / 110°C over the current “F” class of gas turbines and hold the NO_x emission levels at the initial “F” class levels.

The General Electric Company is made up of a number of different businesses. The company has thrived and grown due, in part, to the rapid transfer of improved technology and business practices among these businesses. The primary technology transfer channel is the GE Corporate Research & Development (CR&D) Center located in Schenectady, NY. The *H System*™ new product introduction (NPI) team is also located in Schenectady, facilitating the efficient transfer of technology from CR&D to the NPI team. Formal technology councils, including, for instance, the Thermal Barrier

Coatings Council, High Temperature Materials Council, and the Dry Low NO_x (DLN) Combustion Council, also promote synergy among the businesses, fostering development of advanced technology.

GE Power Systems (GEPS) and GE Aircraft Engines (GEAE) share many common links, including testing facilities for DLN, compressor components, and steam turbine components. In a move which could only have occurred within GE, with its unique in-house resources, over 200 engineers were transferred from GEAE and CR&D to GEPS, to support the development of the *H System*™. These transfers became the core of the *H System*™’s “Design and Systems” teams. *H System*™ technology is shared in its entirety between GEPS and GEAE, including test data and analytical codes.

In contrast to the free exchange of core technical personnel between GEPS and GEAE, several of GE’s competitors have been forced to purchase limited aircraft engine technology from outside companies. This approach results in the acquisition of a specific design with limited detail and flexibility, but with no understanding of the underlying core technology.

In contrast, the transfer from GE Aircraft Engines to GEPS includes, but is not limited to, the following technologies, which are described later in the paper:

- Compressor aerodynamics, mechanical design and scale model rig testing
- Full-scale combustor testing at operating pressures and temperatures
- Turbine aerodynamics, heat transfer, and nozzle cascade testing
- Transfer of materials and coating data
- Processing for turbine blade and wheel superalloys

- Gas turbine instrumentation application and monitoring.

Technology contributed by CR&D includes:

- Development of heat transfer and fluid flow codes
- Process development for thermal barrier coatings
- Materials characterization and data
- Numerous special purpose component and subsystem tests
- Design and introduction of non-destructive evaluation techniques.

Conceptual Design

The GE *H System*TM is a combined-cycle plant. The hot gases from the gas turbine exhaust proceed to a downstream boiler or heat recovery steam generator (HRSG). The resulting steam is passed through a steam turbine and the steam turbine output then augments that from the gas turbine. The output and efficiency of the steam turbine’s “bottoming cycle” is a function of the gas turbine exhaust temperature.

For a given firing temperature class, 2600°F / 1430°C for the *H System*TM, the gas turbine exhaust temperature is largely determined by the work required to drive the compressor, that is, in turn, affected by the “compressor pressure ratio”. The *H System*TM’s pressure ratio of 23:1 was selected to optimize the combined-cycle performance, while at the same time allowing for an uncooled last-stage gas turbine bucket, consistent with past GEPS practice.

The 23:1 compressor-pressure ratio, in turn, determined that using four turbine stages would provide the optimum performance and cost solution. This is a major change from the earlier “F” class gas turbines, which used a 15:1 compressor-pressure ratio and three turbine

stages. With the *H System*TM’s higher pressure ratio, the use of only three turbine stages would have increased the loading on each stage to a point where unacceptable reduction in stage efficiencies would result. By using four stages, the H turbine is able to specify optimum work loading for each stage and achieve high turbine efficiency.

The Case for Steam Cooling

The GE *H System*TM gas turbine uses closed-loop steam cooling of the turbine. This unique cooling system allows the turbine to fire at a higher temperature for increased performance, yet without increased combustion temperatures or their resulting increased emissions levels. It is this closed-loop steam cooling that enabled the combined-cycle GE *H System*TM to achieve 60% fuel efficiency while maintaining adherence to the strictest, low NO_x standards (*Figure 1*).

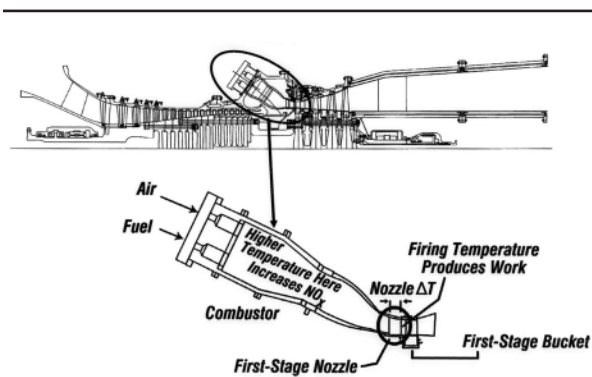

Figure 1. Combustion and firing temperatures

Combustion temperature must be as low as possible to establish low NO_x emissions, while the firing temperature must be as high as possible for optimum cycle efficiency. The goal is to adequately cool the stage 1 nozzle, while minimizing the decrease in combustion product temperature as it passes through the stage 1 nozzle. This is achieved with closed-loop steam cooling.

In conventional gas turbines, with designs pre-dating the *H System*TM, the stage 1 nozzle is cooled with compressor discharge air. This cooling process causes a temperature drop across the stage 1 nozzle of up to 280°F/155°C. In *H System*TM gas turbines, cooling the stage 1 nozzle with a closed-loop steam coolant reduces the temperature drop across that nozzle to less than 80°F/44°C (Figure 2). This results in a firing temperature class of 2600°F/1430°C, or 200°F/110°C higher than in preceding systems, yet with no increase in combustion temperature. An additional benefit of the *H System*TM is that while the steam cools the nozzle, it picks up heat for use in the steam turbine, transferring what was traditionally waste heat into usable output. The third advantage of closed-loop cooling is that it minimizes parasitic extraction

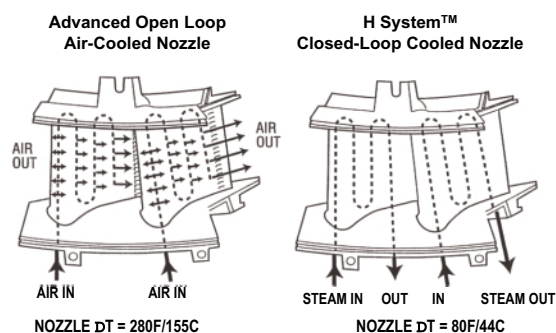

Figure 2. Impact of stage 1 nozzle cooling method

of compressor discharge air, thereby allowing more to flow to the head-end of the combustor for fuel premixing.

In conventional gas turbines, compressor air is also used to cool rotational and stationary components downstream of the stage 1 nozzle in the turbine section. This air is traditionally labeled as “chargeable air”, because it reduces cycle performance. In *H System*TM gas turbines, this “chargeable air” is replaced with steam, which

enhances cycle performance by up to 2 points in efficiency, and significantly increases the gas turbine output, since all the compressor air can be channeled through the turbine flowpath to do useful work. A second advantage of replacing “chargeable air” with steam accrues to the *H System*TM's cycle through recovery of the heat removed from the gas turbine in the bottoming cycle.

H Technology, Combined-Cycle System

The H technology, combined-cycle system consists of a gas turbine, a three-pressure-level HRSG and a reheat steam turbine.

The features of the combined-cycle system, which include the coolant steam flow from the steam cycle to the gas turbine, are shown in Figure 3. The high-pressure steam from the HRSG is expanded through the steam turbine's high-pressure section. The exhaust steam from this turbine section is then split. One part is returned to the HRSG for reheating; the other is combined with intermediate-pressure (IP) steam and used for cooling in the gas turbine.

Steam is used to cool the stationary and rotational parts of the gas turbine. In turn, the heat transferred from the gas turbine increases the steam temperature to approximately reheat temperature. The gas turbine cooling steam is returned to the steam cycle, where it is mixed with the reheated steam from the HRSG and introduced to the IP steam turbine section. Further details about the H combined-cycle system and its operation can be found in GER 3936A, “Advanced Technology Combined-Cycles” and will not be repeated in this paper.

H Product Family and Performance

The H technology, with its higher pressure ratio and higher firing temperature design, will establish a new family of gas turbine products. The 9H and 7H combined-cycle specifications

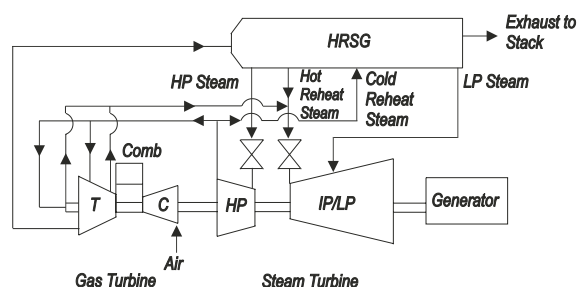

Figure 3. H Combined-cycle and steam description are compared in *Tables 1 and 2* with the similar “F” technology family members.

The 9H and 7H are not scaled geometrically to one another. This is a departure from past prac-

	9FA	9H
Firing Temperature Class, F (C)	2400 (1316)	2600 (1430)
Air Flow, lb/sec (kg/sec)	1376 (625)	1510 (685)
Pressure Ratio	15	23
Combined Cycle Net Output, MW	391	480
Net Efficiency, %	56.7	60
NO_x (ppmvd at 15% O₂)	25	25

Table 1. H Technology performance characteristics (50 Hz)

	7FA	7H
Firing Temperature Class, F (C)	2400 (1316)	2600 (1430)
Air Flow, lb/sec (kg/sec)	953 (433)	1230 (558)
Pressure Ratio	15	23
Combined Cycle Net Output, MW	263	400
Net Efficiency, %	56.0	60
NO_x (ppmvd at 15% O₂)	9	9

Table 2. H Technology performance characteristics (60 Hz)

tices within the industry, but has been driven by customer input to GE. The specified output of the H technology products is 400 MW at 60 Hz and 480 MW at 50 Hz in a single-shaft, combined-cycle system. The 9H has been introduced at 25 ppm NO_x, based on global market needs and economics.

One extremely attractive feature of the H technology, combined-cycle power plants is the high specific output. This permits compact plant designs with a reduced “footprint” when compared with conventional designs, and consequently, the potential for reduced plant capital costs (*Figure 4*). In a 60 Hz configuration, the H technology’s compact design results in a 54% increase in output over the FA plants with an increase of just 10% in plant size.

GE is moving forward concurrently with development of the 9H and 7H. However, in response to specific customer commitments, the 9H was

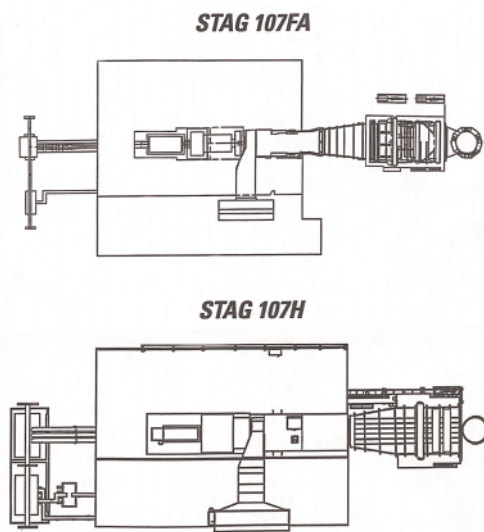

Figure 4. 7H and 7FA footprint comparison

introduced first. The 7H program is following closely, about 12 months behind the 9H.

The 7H development has made progress as part of the Advanced Turbine Systems program of the U.S. Department of Energy and its encouragement and support is gratefully acknowledged.

System Strategy and Integration

While component and subsystem validation is necessary and is the focus of most NPI pro-

grams, other factors must also be considered in creating a successful product. The gas turbine must operate as a system, combining the compressor, combustor and turbine at design point (baseload), at part load turndown conditions, and at no load. The power plant and all power island components must also operate at steady state and under transient conditions, from start-up, to purge, to full speed.

Unlike traditional combined-cycle units, the *H System*TM gas turbine, steam turbine and HRSG are linked into one, interdependent system. Clearly, the reasoning behind these GE *H System*TM components runs contrary to the traditional approach, which designs and specifies each component as a stand-alone entity. In the *H System*TM, the performance of the gas turbine, combined-cycle and balance of plant has been modeled, both steady state and transient; and analyzed in detail, as one large, integrated system, from its inception.

The GE *H System*TM concept incorporates an integrated control system (ICS) to act as the glue, which ties all the subsystems together (*Figure 5*).

Systems and controls teams, working closely with one another as well as with customers, have formulated improved hardware, software, and control concepts. This integration was facilitat-

ed by a new, third-generation, full-authority digital system, the Mark VI controller. This control system was designed with and is supplied by GE Industrial Systems (GEIS), which is yet another GE business working closely with GEPS.

The control system for the *H System*TM manages steam flows between the HRSG, steam turbine and gas turbine. It also schedules distribution of cooling steam to the gas turbine. A diagnostic capability is built into the control system, which also stores critical data in an electronic historian for easy retrieval and troubleshooting.

The development of the Mark VI and integrated control system has been deliberately scheduled ahead of the H gas turbine to reduce the gas turbine risk. With the help of GE CR&D, the Mark VI followed a separate and rigorous NPI risk abatement procedure, which included proof of concept tests and shake down tests of a full combined-cycle plant at GE Aircraft Engines in Lynn, Massachusetts.

The Systems and controls teams have state-of-the-art computer simulations at their disposal to facilitate full engineering of control and fallback strategies. Digital simulations also serve as a training tool for new operators.

Simulation capability was used in real time during the 9H Full-Speed No-Load (FSNL)-1 test in May 1998. This facilitated revision of the accelerating torque demand curves for the gas turbine and re-setting of the starter motor current and gas turbine combustor fuel schedule. The end result was an automated, one-button, soft-start for the gas turbine, which was used by the TEPCO team to initiate the May 30, 1998 customer witness test.

The balance of this paper will focus on the gas turbine and its associated development program.

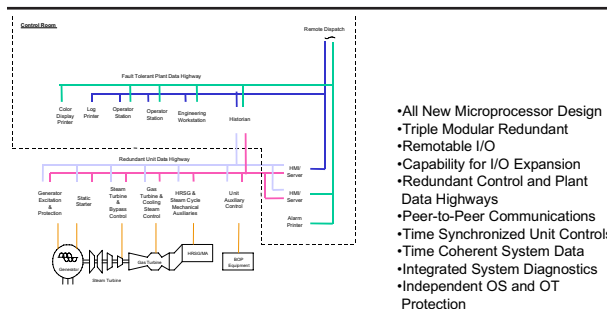

Figure 5. Mark VI – ICS design integrated with *H Systems*TM design

H Gas Turbine

The heart of the GE *H System*[™] is the gas turbine. The challenges, design details, and validation program results follow. We start with a brief overview of the 9H and 7H gas turbine components (*Figure 6*).

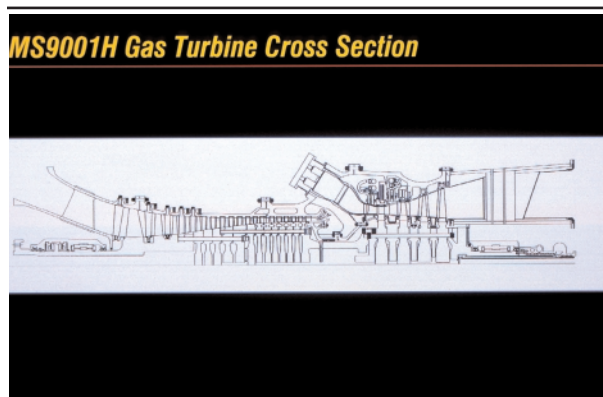

Figure 6. Cross-section H gas turbine

Compressor Overview

The H compressor provides a 23:1 pressure ratio with 1510 lb/s (685 kg/s) and 1230 lb/s (558 kg/s) airflow for the 9H and 7H gas turbines, respectively. These units are derived from the high-pressure compressor GE Aircraft Engines (GEAE) used in the CF6-80C2 aircraft engine and the LM6000 aeroderivative gas turbine. For use in the H gas turbines, the CF6-80C2 compressor has been scaled up (2.6:1 for the MS7001H and 3.1:1 for the MS9001H) with four stages added to achieve the desired combination of airflow and pressure ratio. The CF6 compressor design has accumulated over 20 million hours of running experience, providing a solid design foundation for the *H System*[™] gas turbine.

In addition to the variable inlet guide vane (IGV), used on prior GE gas turbines to modulate airflow, the H compressors have variable stator vanes (VSV) at the front of the compressor. They are used, in conjunction with the IGV,

to control compressor airflow during turn-down, as well as to optimize operation for variations in ambient temperature.

Combustor Overview

The *H System*[™] can-annular combustion system is a lean pre-mix DLN-2.5 *H System*[™], similar to the GE DLN combustion systems in FA-class service today. Fourteen combustion chambers are used on the 9H, and twelve combustion chambers are used on the 7H. DLN combustion systems have demonstrated the ability to achieve low NO_x levels in field service and are capable of meeting the firing temperature requirements of the GE *H System*[™] gas turbine while obtaining single-digit (ppm) NO_x and CO emissions.

Turbine Overview

The case for steam cooling was presented earlier under Conceptual Design. The GE *H System*[™] gas turbine's first two stages use closed-loop steam cooling, the third stage uses air cooling, while the fourth and last stage is uncooled.

Closed-loop cooling eliminates the film cooling on the gas path side of the airfoil, and increases the temperature gradients through the airfoil walls. This method of cooling results in higher thermal stresses on the airfoil materials, and has led GEPS to use single-crystal super-alloys for the first stage, in conjunction with thin ceramic thermal barrier coatings (*Figure 7*). This is a combination that GEAE has employed in its jet engines for 20 years. GEPS reached into the extensive GEAE design, analysis, testing and production database and worked closely with GEAE, its supplier base, and CR&D to translate this experience into a reliable and effective feature of the *H System*[™] gas turbine design.

GE follows a rigorous system of design practices which the company has developed through hav-

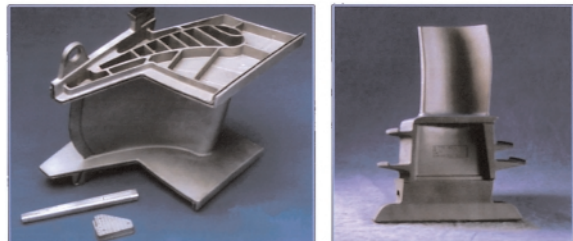

Figure 7. H Stage 1 nozzle and bucket – single crystal

ing a wide range of experiences with gas turbines in the last 20 years. For instance, GEAE’s experience base of over 4000 parts indicates that thermal barrier coating on many airfoils is subject to loss early in operation, and that maximization of coating thickness is limited by deposits from environmental elements, evidenced by coating spallation when thickness limits are exceeded. Through laboratory analyses and experience-based data and knowledge, GE has created an airfoil that has shown, during field tests, that it maintains performance over a specific minimum cyclic life coatings, even with localized loss of coatings, as has been noted during field service.

Gas Turbine Validation: Testing to Reduce Risk

Although GEPS officially introduced the *H System*[™] concept and two product lines, the 9H and 7H gas turbines, to the industry in 1995, *H System*[™] technology has been under development since 1992. The development has been a joint effort among GEPS, GEAE, and CR&D, with encouragement and support from the U.S. Department of Energy, and has followed GE’s comprehensive design and technology validation plan that will, when complete, have spanned 10 years from concept to power plant commissioning.

The systematic design and technology-validation approach described in this paper has proved to be the aerospace and aircraft industry’s most reliable practice for introduction of complex, cutting-edge technology products. The approach is costly and time consuming, but is designed to deliver a robust product into the field for initial introduction. At its peak, the effort to develop and validate the *H System*[™] required the employment of over 600 people and had annual expenses of over \$100 million.

Other suppliers perceive that design and construction of a full-scale prototype may be a faster development-and-design approach. However, it is difficult, if not impossible, for a prototype to explore the full operating process in a controlled fashion. For example, prototype testing limits the opportunity to evaluate alternative compressor stator gangs and to explore cause-and-effect among components when problems are encountered. The prototype approach also yields a much greater probability of failure during the initial field introduction of a product than does the comprehensive design approach, coupled with “Six Sigma” disciplines and the technology validation plan used by GE (*Figure 8*).

The first phase in the *H System*[™] development process was a thorough assessment of product options, corresponding design concepts, and system requirements. Also crucial in the first phase was careful selection of materials, components and subsystems. These were sorted into categories of existing capabilities or required technology advancements. All resources and technological capabilities of GEAE and CR&D were made available to the Power Systems’ H-technology team.

For each component and subsystem, risk was assessed and abatement analyses, testing, and

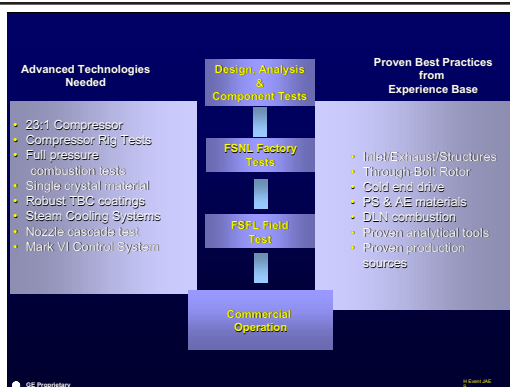

Figure 8. GE validation process

data were specified. Plans to abate risk and facilitate design were arranged, funded, and executed.

The second development phase covered product conceptual and preliminary designs, and included the introduction of knowledge gained through experience, materials data, and analytical codes from GEPS and GEAE.

The *H System*[™] development program is currently in its third and final phase, technology readiness demonstration. This phase includes execution of detailed design and product validation through component and gas turbine testing. A high degree of confidence has been gained through component and subsystem testing and validation of analysis codes. Completion of the development program results in full-scale gas turbine testing at our factory test stand in Greenville, SC, followed by combined-cycle power plant testing at the Baglan Energy Park launch site, in the United Kingdom.

Compressor Design Status

Modifications and proof-of-design are made through a rigorous design process that includes GEAE and GEPS experience-based analytical tools, component tests, compressor rig tests and instrumented product tests. The aerodynamic

design process uses pitchline design and off-design performance evaluation, axisymmetric streamline curvature calculations with empiricism for secondary flows and mixing, two-dimensional inviscid blade-to-blade analysis and three dimensional viscous CFD blade row analysis. The aerodynamic design is iterated in concert with the aeromechanical design of the individual blade stages, optimizing on GEAE and GEPS experience-supported limits on blade loading, stage efficiency, surge margin, stress limits, etc.

The program has completed the third and final compressor rig test at GEAE’s Lynn, MA test facility.

Tests are run with CF6 full-scale hardware, which amounts to a one-third scale test for the 9H and 7H gas turbines. Each rig test is expensive, approximately \$20M, but provides validation and flexibility, significantly surpassing any other test options. The 7H rig test had over 800 sensors and accumulated over 150 hours to characterize the compressor’s aerodynamic and aeromechanical operations (*Figure 9*). Key test elements include optimum ganging of the variable guide vanes and stators; performance mapping to quantify airflow, efficiency, and stall margins; stage pressure and temperature splits; start-up, acceleration, and turndown character-

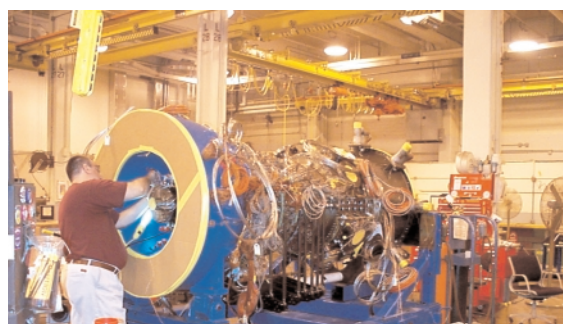

Figure 9. 7H compressor test rig

istics; and identification of flutter and vibratory characteristics of the airfoils (aeromechanics).

The three-test series has accomplished the following:

- Proof of concept, with four stages added to increase pressure ratio, and initial power generation operability – completed August 1995.
- 9H compressor design validation and maps including tri-passage diffuser performance and rotor cooling proof-of-concept – completed August 1997.
- 7H compressor design validation – completed August 1999, (*Figure 10*)

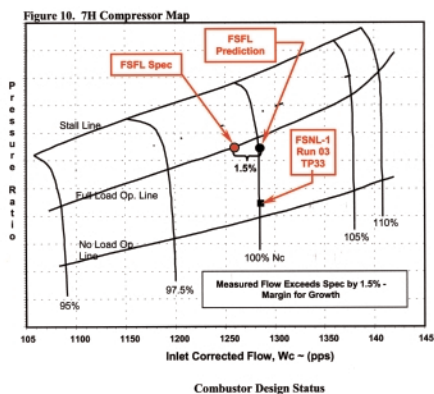

Figure 10. Compressor map

Combustor Design Status

Figure 11 shows a cross-section of the combustion system. The technical approach features a tri-passage radial prediffuser which optimizes the airflow pressure distribution around the combustion chambers, a GTD222 transition piece with an advanced integral aft frame mounting arrangement, and impingement sleeve cooling of the transition piece. The transition piece seals are the advanced cloth variety for minimum leakage and maximum wear resistance. The flow sleeve incorporates

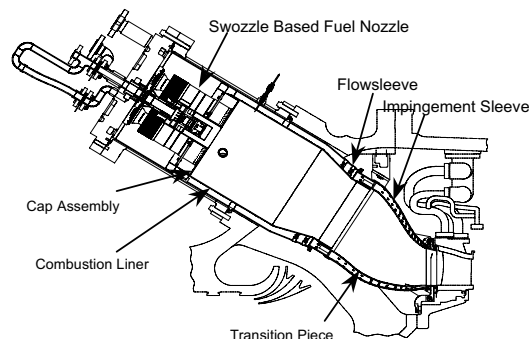

Figure 11. Combustion system cross-section

impingement holes for liner aft cooling. The liner cooling is of the turbolator type so that all available air can be allocated to the reaction zone to reduce NO_x . Advanced 2-Cool™ composite wall convective cooling is utilized at the aft end of the liner. An effusion-cooled cap is utilized at the forward end of the combustion chamber.

Fuel Injector Design Status

The *H System*™ fuel injector is shown in *Figure 12* and is based on the swizzle concept. The term swizzle is derived by joining the words “swirler” and “nozzle.” The premixing passage of the swizzle utilizes swirl vanes to impart rotation to the admitted airflow, and each of these swirl vanes also contains passages for injecting fuel into the premixer airflow. Thus, the premixer is very aerodynamic and highly resistant

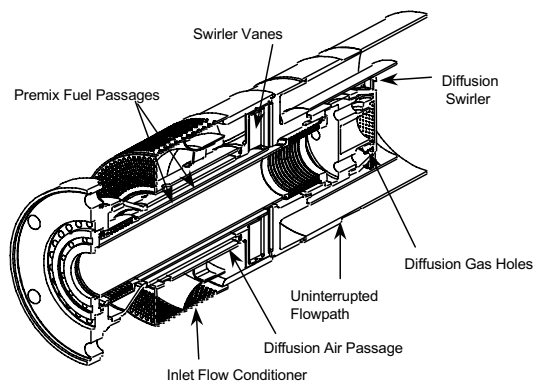

Figure 12. Fuel injector system cross-section

to flashback and flameholding. Downstream of the swizzle vanes, the outer wall of the premixer is integral to the fuel injector to provide added flameholding resistance. Finally, for diffusion flame starting and low load operation, a swirl cup is provided in the center of each fuel injector.

The *H System*TM combustor uses a simplified combustion mode staging scheme to achieve low emissions over the premixed load range while providing flexible and robust operation at other gas turbine loads. *Figure 13* shows a schematic diagram of the staging scheme. The most significant attribute is that there are only

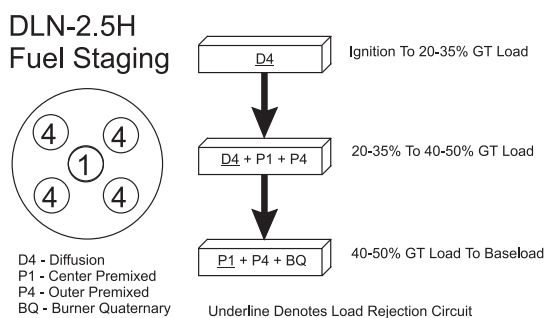

Figure 13. Combustion mode staging scheme

three combustion modes: diffusion, piloted premix, and full premix mode. These modes are supported by the presence of four fuel circuits: outer nozzle premixed fuel (P4), center nozzle premixed fuel (P1), burner quaternary premixed fuel (BQ), and diffusion fuel (D4). The gas turbine is started on D4, accelerated to Full-Speed No-Load (FSNL), and loaded further. At approximately 20-35% gas turbine load, two premixed fuel streams P1, and P4, are activated in the transfer into piloted premix. After loading the gas turbine to approximately 40-50% load, transfer to full premix mode is made and all D4 fuel flow is terminated while BQ fuel flow is activated. This very simplified staging strategy has major advantages for smooth unit operability and robustness.

The *H System*TM combustor was developed in an extensive test series to ensure low emissions, quiet combustion dynamics, ample flashback/flameholding resistance, and rigorously assessed component lifing supported by a complete set of thermal data. In excess of thirty tests were run at the GEAE combustion test facility, in Evendale, OH, with full pressure, temperature, and airflow. *Figure 14* shows typical NO_x baseload emissions as a function of combustor exit temperature, and *Figure 15* shows the comparable combustion dynamics data. The H components have significant margin in each case. In addition, hydrogen torch

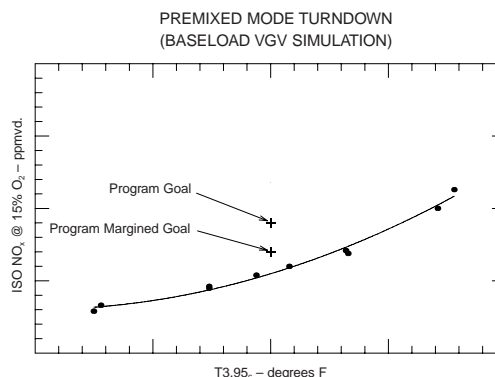

Figure 14. NO_x baseload emissions as a function of combustor exit temperature

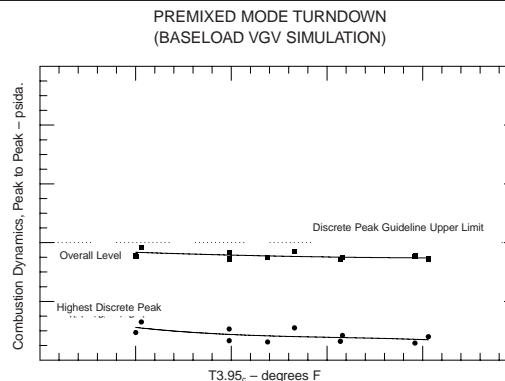

Figure 15. Comparable combustion dynamics data

ignition testing was performed on the fuel injector premixing passages. In all cases the fuel injectors exhibited well in excess of 30 ft/s flameholding margin after the hydrogen torch

was de-activated. In addition, lifing studies have shown expected combustion system component lives with short term Z-scores between 5.5 and 7.5 relative to the combustion inspection intervals on a thermal cycles to crack initiation basis. Thus, there is a 99.9% certainty that component lifing goals will be met.

Turbine Design Status

The turbine operates with high gas path temperatures, providing the work extraction to drive the compressor and generator. Two of the factors critical to reliable, long life are the turbine airfoil's heat transfer and material capabilities. When closed circuit steam cooling is used, as on the H turbine, the key factors do not change. However, the impact of steam on the airfoil's heat transfer and material capabilities must also be considered.

For many years, the U.S. Department of Energy (DOE) Advanced Turbine System has provided cooperative support for GE's development of the H System™ turbine heat transfer materials capability and steam effects. Results have fully defined and validated the factors vital to successful turbine operation. A number of different heat transfer tests have been performed to fully characterize the heat transfer characteristics of the steam-cooled components. *Figure 16*



Figure 16. Full-scale stage 1 nozzle heat transfer test validates design and analysis predictions

shows results for stage 1 nozzle internal cooling heat transfer. An extensive array of material tests has been performed to validate the material characteristics in a steam environment. Testing has included samples of base material and joints and the testing has addressed the following mechanisms: cyclic oxidation, fatigue crack propagation, creep, low-cycle fatigue and notched low-cycle fatigue (*Figure 17*).

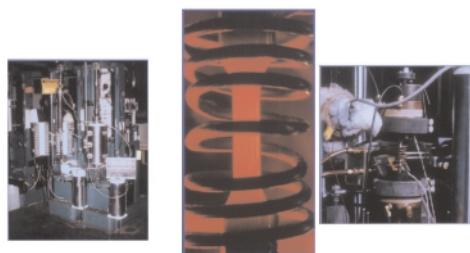

Figure 17. Materials validation testing in steam

Thermal barrier coating (TBC) is used on the flowpath surfaces of the steam-cooled turbine airfoils. Life validation has been performed using both field trials (*Figure 18*) and laboratory analysis. The latter involved a test that duplicates thermal-mechanical conditions, which the TBC will experience on the H System™ airfoils. Long-term durability of the steam-cooled components is dependent on avoidance of internal deposit buildup, which is, in turn, dependent on steam purity. This is accomplished through system design and filtration of the gas turbine cooling steam. Long-term validation testing,

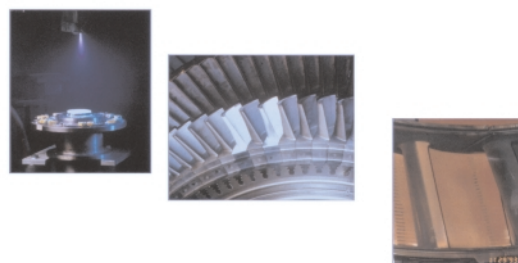

Figure 18. Thermal barrier coating durability

currently underway at an existing power plant, has defined particle size distribution and validated long-term steam filtration. As further validation, specimens duplicating nozzle cooling passages have initiated long-term exposure tests. A separate rotational rig is being used for bucket validation.

The H turbine airfoils have been designed using design data and validation test results for heat transfer, material capability and steam cooling effects. The durability of ceramic thermal barrier coatings has been demonstrated by three different component tests performed by CR&D:

- Furnace cycle test
- Jet engine thermal shock tests
- Electron beam thermal gradient testing

The electron beam thermal gradient test was developed specifically for GEPS to accurately simulate the very high heat transfers and gradients representative of the *H System*[™] gas turbine. Heat transfers and gradients representative of the *H System*[™] gas turbine have also been proven by field testing of the enhanced coatings in E- and F-class gas turbines.

The stage 1 nozzle, which is the *H System*[™] component subjected to the highest operating temperatures and gradients, has been validated by another intensive component test. A nozzle cascade facility was designed and erected at GEAE (*Figure 19*). It features a turbine segment carrying two closed-loop steam-cooled nozzles downstream from a full-scale *H System*[™] combustor and transition piece. This testing facility accurately provides the actual gas turbine operating environment. Two prototype nozzles complete with pre-spalled TBC were tested in April 1998. Data was obtained validating the aerodynamic design and heat transfer codes. Accelerated endurance test data was also

obtained. A second test series, with actual 9H production nozzles, is scheduled to start in the 4th quarter of 2000).



Figure 19. Nozzle cascade test facility

The rotor steam delivery system delivers steam for cooling stage 1 and 2 turbine buckets. This steam delivery system relies on “spoolies” to deliver steam to the buckets without detrimental leakage, which would lead to performance loss and adverse thermal gradients within the rotor structure. The basic concept for power system steam sealing is derived from many years of successful application of spoolies in the GE CF6 and CFM56 aircraft engine families.

In the conceptual design phase, material selection was made only after considering the effects of steam present in this application. Coatings to improve durability of the spoolie were also tested. These basic coupon tests and operational experience provided valuable information to the designers.

In the preliminary design phase, parametric analysis was performed to optimize spoolie configuration. Component testing began for both air and steam systems. The spoolie was instrumented to validate the analysis. Again, the combination of analysis and validation tests provided confirmation that the design(s) under consideration were based on the right concept.

Over 50 component tests have been conducted on these spoolies, evaluating coatings, lateral loads, fits, axial motion, angular motion, temperature and surface finish.

The detailed design phase focused on optimization of the physical features of the subsystem, spoolie-coating seat. In addition, refined analysis was performed to allow for plasticity lifecycle calculations in the region of the highest stresses. This analysis was again validated with a spoolie cyclic life test, which demonstrated effective sealing at machine operating conditions with a life over of 20,000 cycles.

Spoolies were also used on the *H System*TM FSNL gas turbine tests. During the 9H FSNL-2 testing, compressor discharge air flowed through the circuit. This is typical of any no-load operation. Assembly and disassembly tooling and processes were developed. The spoolies were subjected to a similar environment with complete mechanical G loading. Post-testing condition of the seals was correlated to the observation made on the component tests. This provided another opportunity for validation.

A rotating steam delivery rig (*Figure 20*) has been designed and manufactured to conduct cyclic endurance testing of the delivery system under any load environment. The rotating rig will subject components to the same centrifugal

forces and thermal gradients that occur during actual operation of the turbine. This system testing will provide accelerated lifecycle testing.

Leakage checks will be completed periodically to monitor sealing effectiveness. Test rig instrumentation will insure that the machine matches the operating environment. The rig has been installed in the test cell, and testing should resume in April 2000.

Gas Turbine Factory Tests

The first six years of the GE *H System*TM validation program focused on sub-component and component tests. Finally, in May 1998, the program moved on to the next stage, that of full-scale gas turbine testing at the Greenville, South Carolina factory (*Figure 21*). The 9H gas turbine achieved first fire and full speed and, then, over a space of five fired tests, accomplished the full set of objectives. These objectives included confirmation of rotor dynamics: vibration levels and onset of different modes; compressor airfoil aero-mechanics; compressor performance, including confirmation of airflow and efficiency scale-up effects vs. the CF6 scale rig tests; measurement of compressor and turbine rotor clearances; and demonstration of the gas turbine with the Mark VI control system.

The testing also provided data on key systems:

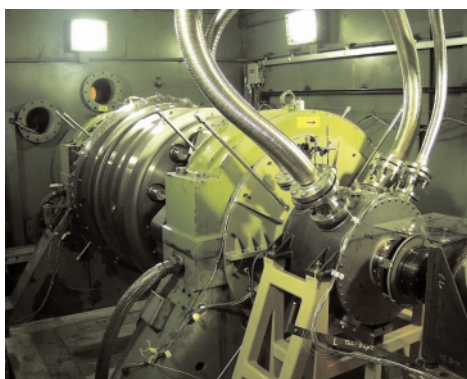

Figure 20. Rotating rig installed in test stand

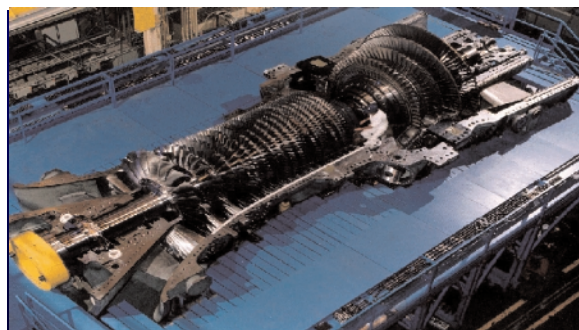

Figure 21. 9H gas turbine in half shell prior to first FSNL test

bearings, rotor cooling, cavity temperatures and effectiveness of the clearance control systems.

Following the testing, the gas turbine was disassembled in the factory and measured and scrutinized for signs of wear and tear. The hardware was found to be in excellent condition.

The 9H gas turbine was rebuilt with production turbine airfoils and pre-shipment tests performed in October and November 1999. This unit was fully instrumented for the field test to follow and, thus, incorporated over 3500 gauges and sensors (*Figure 22*).



Figure 22. 9H gas turbine in test stand for pre-shipment test

This second 9H test series took seven fired starts and verified that the gas turbine was ready to ship to the field for the final validation step. Many firsts were accomplished. The pre-shipment test confirmed that the rotating air/steam cooling system performed as modeled and designed. In particular, leakage, which is critical to the cooling and life of the turbine airfoils and the achievement of well-balanced and predictable rotor behaviors, was well under allowable limits.

Compressor and turbine blade aeromechanics data were obtained at rates of up to 108% of the design speed, clearing the unit to run at design and over-speed conditions. Rotor dynamics

were once again demonstrated, and vibration levels were found to be acceptable without field balance weights.

The Mark VI control system demonstrated full control of both the gas turbine and the new *H System™* accessory and protection systems.

The first 7H gas turbine was assembled and moved to the test stand in December 1999 (*Figure 23*). This 7H went through a test series similar to that for the first 9H factory test. However, the 7H not only covered the 9H test objectives described earlier, but also ran separately with deliberate unbalance at compressor and turbine ends to characterize the rotor sensitivity and vectors. The rotor vibrations showed excellent correlation with the rotor dynamic model and analysis.

The 7H gas turbine is now back in the factory for disassembly and inspection, following the same sequence used for the 9H.



Figure 23. 7H gas turbine being installed in test stand

Validation Summary

GE is utilizing extensive design data and validation test programs to ensure that a reliable *H System™* power plant is delivered to the customer. A successful baseline compressor test program has validated the *H System™* compressor design approach. As a result of the 9H and

7H compressor tests, the H compressors have been fully validated for commercial service. The H turbine airfoils have been validated by extensive heat tests, materials testing in steam, TBC testing and steam purity tests. Test results have been integrated into detailed, three-dimensional, aerodynamic, thermal and stress analysis. Full size verification of the stage 1 nozzle design is being achieved through the steam-cooled nozzle cascade testing.

Both 9H and 7H gas turbines have undergone successful factory testing and the 9H is now poised for shipment to the field and final validation test.

Conclusion

The rigorous design and technology validation of the *H System*[™] is an illustration of the GE NPI process in its entirety. It began with a well-reasoned concept that endured a rigorous review

and validation process. This ensures the highest probability of success, even before the product or shipping to customers and/or the product has begun operation in the field.

The H technology, combined-cycle power plant creates an entirely new echelon of power generation systems. Its innovative cooling system allows a major increase in firing temperature, which allows the turbine to reach record levels of efficiency and specific work while retaining low emissions capability.

The design for this “next generation” power generation system is now established. Both the 50 Hz and 60 Hz family members are currently in the production and final validation phase. The extensive component test validation program, already well underway, will ensure delivery of a highly reliable, combined-cycle power generation system to the customer.

List of Figures

- Figure 1. Combustion and firing temperatures
- Figure 2. Impact of stage 1 nozzle cooling method
- Figure 3. H combined-cycle and system description
- Figure 4. 7H and 7FA footprint comparison
- Figure 5. Mark VI – ICS design integrated with *H System*TM design
- Figure 6. Cross-section H gas turbine
- Figure 7. H Turbine - stage 1 nozzle and bucket – single crystal
- Figure 8. GE validation process
- Figure 9. 7H compressor rig test
- Figure 10. Compressor map
- Figure 11. Combustion system cross-section
- Figure 12. Fuel injection system cross-section
- Figure 13. Combustion mode staging scheme
- Figure 14. Combustion test results – NO_x baseload emissions as a function of combustion exit temperature
- Figure 15. Combustion test results – comparable combustion dynamics data
- Figure 16. Full-scale stage 1 nozzle complete band heat transfer test validates cooling design
- Figure 17. Materials validation testing in steam
- Figure 18. Thermal barrier coating durability
- Figure 19. Nozzle cascade test facility
- Figure 20. Rotating rig installed in test stand
- Figure 21. 9H gas turbine in half shell prior to first FSNL test
- Figure 22. 9H gas turbine in test stand for pre-shipment test
- Figure 23. 7H gas turbine being installed in test stand

List of Tables

- Table 1. H Technology performance characteristics (50 Hz)
- Table 2. H Technology performance characteristics (60 Hz)

